

**WARRANTY &
MAINTENANCE
MANUAL**

Dear ROX 01 Vehicle owner!

Thank you for choosing the ROX brand vehicle. ROX has provided all necessary support for convenience and satisfaction of our owners first! Modern technology, high-quality production, and components ensure the smooth operation of ROX vehicles. Any malfunctions or deterioration in consumer performance caused by production defects will be repaired according to the warranty terms. Follow the following suggestions.

The 'Warranty & Maintenance Manual', owning a ROX will be as comfortable as possible. Official Dealers have obtained professional maintenance certification, including diagnostic equipment, special tools, genuine spare parts, and technicians.

Vehicle Registration Card

Vehicle Information

Model: _____

Identification Number (VIN): _____

Color: _____

Equipment: _____

Pre-sales preparation date: _____

Warranty start date: _____

Owner Information

Name of owner/Legal entity: _____

Contact phone number: _____

Email: _____

Postal address: _____

Dealer Signature

Owner Signature

Signature/Seal:

Signature/Seal:

Date:

Date:

Change of Ownership Registration Card

If the Vehicle's owner changes, please contact the official ROX Dealer's service center for registration.

New owner information

Name of owner/legal representative:

Contact phone number:

E-mail:

Postal address:

Transfer Date

Transfer Mileage

KM

Change of Ownership Registration Card

If the Vehicle's owner change, please contact the official ROX Dealer's service center for registration.

New owner information

Name of owner/legal representative:

Contact phone number:

E-mail:

Postal address:

Transfer Date

Transfer Mileage

KM

Dear ROX 01 Vehicle owner!

The information contained in this Warranty & Maintenance Manual is crucial for ensuring the continuous and safe operation of your ROX vehicle during the warranty period.

Please keep the Warranty & Maintenance Manual. This Warranty & Maintenance Manual must be submitted to the Dealer to confirm your warranty rights. When selling a vehicle, please hand over the Warranty & Maintenance Manual to the next owner.

Please read the Warranty & Maintenance Manual carefully. Regularly doing maintenance of your ROX vehicle according to the maintenance standards and schedule mentioned in Warranty & Maintenance Manual accurately. If maintenance is required, please contact the official service center of ROX.

Be careful! If there is no pre-sales service, the sale of vehicles is prohibited.

Before handing over the vehicle to you, the official Dealer must ensure that you are fully familiar with its equipment and controls; And explain to you the working principle of all vehicle controls and allow you to check their operation; Write information about the vehicle and its owner into the relevant sections of the Warranty & Maintenance Manual; Ensure that you receive the Warranty & Maintenance Manual and explain the requirements for planned maintenance; Explain the terms of the manufacturer's warranty obligations applicable to new vehicles and listed in this Warranty & Maintenance Manual.

1.1 Warranty scope

1.1.1 Warranty scope

- During the warranty period of ROX 01, if the vehicle is damaged due to the design, manufacturing, assembly or raw material defects of the product, the local service center will provide the warranty service and bear the expenses.
- During the warranty period of the power battery, if the capacity of the power battery decreases below 70%, the local service center will provide free repair or replacement of the power battery for the user.
- The warranty is only applicable within the territory of the vehicle purchase country and applied by authorized Distributor and Dealers.

1.2 Warranty period

1.2.1 Vehicle Warranty period of whole vehicle

The warranty period of the whole vehicle and related parts is as follows:

Classification	Types and scope of parts	Warranty period
Whole vehicle	The whole vehicle and the following unspecified parts	5 years or 150,000km
Three-electric Key parts	Power battery, driving motor and its controller	8 years or 240,000km
	Range extender (engine), generator	5 years or 150,000km
Consumable parts	Air conditioning filter	10,000km
	Wiper blade	10,000km
	Brake pad	20,000km
	Tire	10,000km
	Battery (12V)	4 years or 80,000km

1 Warranty Manual

Classification	Types and scope of parts	Warranty period
Consumable parts	Remote control battery	20,000km
	Bulb	20,000km
	Fuses and ordinary relays (excluding integrated control units)	20,000km
	Oil filter	10,000km
	Air filter	10,000km
	Spark plug	20,000km

Notes:

- The vehicle warranty period shall be calculated from the date of the invoice issued to the end user, but shall not be later than 180 days after the actual date of whole sale (the date when Party A sells the car to Party B).
- The warranty period in the table shall be based on the time and mileage whichever comes first.
- For parts, accessories or fine products whose warranty period is otherwise agreed with users, the agreed warranty period shall prevail.
- The work completed by fulfilling the warranty responsibility shall not extend the warranty period of the product. During the warranty period, parts, accessories or fine products that are replaced on the vehicle for free shall have the same warranty period as the remaining warranty period of the replaced parts, accessories or fine products, and will end with the end of the remaining warranty period of the replaced parts, accessories or fine products. When the ownership of the vehicle changes, the warranty responsibility of the vehicle shall not be terminated, and the vehicle shall still maintain the warranty period specified in this warranty clause.

1.2.2 Warranty period of customer-paid replacement of parts

The warranty period of the customer-paid replacement of parts is as follows:

Classification	Types and scope of parts	Warranty period
Three-electric	Power battery	2 years or 50,000km
	Driving motor and its controller	2 years or 50,000km
Key parts	Range extender (engine), generator	2 years or 50,000km
Consumable parts	Oil filter, Air conditioning filter, Air filter, Tire	6 months or 5,000km
	Wiper blade, Remote control battery, Bulb	6 months or 10,000km
	Spark plug, Brake pad	1 year or 10,000km
	Fuses and ordinary relays (excluding integrated control units)	1 years or 8,000km
	Battery (12V)	1 years or 30,000km
Other parts	The above parts are not specified	1 years or 30,000km

Notes:

- The customer - paid parts warranty period shall be calculated from the date of the parts invoice issued to the end user. If no invoice is issued or the date on the parts invoice is not the same as the delivery date, please refer to the parts delivery date as the start date. The warranty period in the table shall be based on the time and mileage whichever comes first.
- For parts, accessories or fine products whose warranty period is otherwise agreed with users, the agreed warranty period shall prevail.
- The work completed by fulfilling the warranty responsibility shall not extend the warranty period of the product. During the warranty period, parts, accessories or fine products that are replaced on the vehicle for free shall have the same warranty period as the remaining warranty period of the replaced parts, accessories or fine products, and will end with the end of the remaining warranty period of the replaced parts, accessories or fine products. When the ownership of the vehicle changes, the warranty responsibility of the vehicle shall not be terminated, and the vehicle shall still maintain the warranty period specified in this warranty clause.

1.2.3 Warranty period of Body Painting

The warranty period of the vehicle body painting is as follows:

Classification	Types and scope of parts	Warranty period
Body Painting	For ROX original painting	5 years or 150,000km

Note:

- The warranty period for Body Painting is only applicable to the original vehicle body.

1.2.4 Warranty period of Body Anti-corrosion

The warranty period of the vehicle body anti-corrosion is as follows:

Classification	Types and scope of parts	Warranty period
Body Anti-corrosion	For ROX original vehicle body	5 years or 150,000km

Note:

- The warranty period for Body anti-corrosion is only applicable to the original vehicle body.

1.3 Warranty disclaimer

1.3.1 Warranty disclaimer

During the vehicle warranty period, if there are product quality issues with the Household ROX 01, we can assist the owner in handling replacement matters, except for the following situations:

- Normal component wear or aging, such as normal wear and tear of tires, wiper blades, deformation or fading caused by normal aging of rubber, paint, envelope, etc., normal attenuation of chemical energy storage devices such as power battery cells, 12V batteries, and remote key batteries.
- Product quality problems occur after the consumable parts exceed the specified warranty period.
- The vehicle purchased by the user has been notified in writing (including but not limited to the user manual, warranty clause, and purchase contract) that there are defects.
- The vehicle is used for rental, online car-hailing, leasing or other operational purposes.

- The vehicle is used for non-household purposes and conditions such as competition, off-road race, performances and entertainment, experiment, military action, requisition, etc.
- Damage to the vehicle caused by self-modification, adjustment, or disassembly by the user.
- Malfunctions caused by the use of automotive components, oils, and accessories that do not meet the original factory standards, or by the use of products that may damage the vehicle.
- Power battery failure or damage caused by immersing any part of the power battery in water or other liquids.
- Power battery failure or damage caused by the use of non-standard or incompatible charging equipment, or failure to follow the correct charging operation process.
- Vehicle damage caused by improper handling by users due to product quality issues.
- Damage caused by failure to use, maintain, and repair the product correctly in accordance with the usage requirements and maintenance specifications in this manual.
- Failure or damage of the power battery caused by long-term storage of the vehicle for more than 3 months without regular maintenance of the power battery.
- Vehicle damage caused by external environmental factors, such as corrosive chemicals in the air, radioactive dust, tree sap, animal and insect excrement, seawater, acid rain, stones, industrial smoke/dust, hail, earthquake, flood, storm, lightning, etc.
- Vehicle damage caused by incorrect chemical treatment, such as vehicle damage or corrosion caused by improper use of chemicals or sealants.
- Vehicle damage caused by theft, car accidents, traffic accidents, overloading, wading, destruction, riots, explosions, and impact of foreign objects or intentional actions.
- Other damages caused by force majeure, except as mentioned above.

1.4 Responsibility of the vehicle owner during Warranty Period

1.4.1 Owner's attention matters when using vehicle

Vehicle owners must:

1. Follow the vehicle operation and maintenance recommendations in this Warranty & Maintenance Manual and the owner's manual.
2. Provide the vehicle to an official Dealer for warranty.
3. Maintain the vehicle according to the requirements in the "Maintenance" section of this Warranty & Maintenance Manual. If the Dealer needs it, keep the vehicle repair record. The spare parts warranty only applies to the installation of relevant documents.

4. Carefully follow all the recommendations in the "Warranty & Maintenance Manual".
5. Regularly wash the car and handle the body with protective equipment.
6. If salt, sand, asphalt, tar, resin, and other substances that may damage the paint coating are found on the vehicle body, they should be immediately removed and any such damage to the vehicle body paint coating should be promptly eliminated at their own expense.
7. If there is a change in vehicle ownership and/or changes in vehicle and/or owner information, please immediately contact a ROX authorized Dealer to register this information on the replacement registration card in this Warranty & Maintenance Manual.

1.4.2 Vehicle daily maintenance recommendation for Owner

Daily check ups and care.

In the daily operation of the vehicle, the owner must inspect and maintain the vehicle. The scope and frequency of vehicle inspection and maintenance are determined by the owner based on the vehicle's mileage, usage time, and evaluation of its condition during driving. We recommend that you inspect and maintain your vehicle before long-distance travel and during cleaning or refueling.

- Safety measures and requirements for vehicle technical inspection site:
- It is prohibited to conduct inspections in places that obstruct pedestrians or traffic.
- Do not conduct inspections in tilted areas, for example. appendix Vehicles may move, posing a risk of injury.
- To avoid accidental injury, the inspection should only begin after the wheels have completely stopped rotating and the vehicle has been placed on the parking brake.
- Check the safety measures of the car cabin:
- Do not check while the engine is running - this is very dangerous.
- Do not check during ignition - this may cause injury.
- To avoid burns, do not immediately touch the exhaust pipe and radiator after the engine is turned off.
- It is prohibited to place foreign objects, especially paper, fabrics, and other flammable materials, in the cabin to avoid fire.
- To avoid malfunctions, do not disconnect hoses and wires

2.1 Maintenance and repair

2.1.1 New car run-in

I. Brake gear

After the vehicle runs about 500 km, the brake disc and brake pad can achieve better braking performance. Therefore, during this running-in period, please drive with caution.

II. Tire

The adhesion performance of new tires is not at its best. For the first 300 km, i.e., the running-in period, drive at appropriate speeds and with caution. This can extend the tire's lifespan and enhance safety.

III. After replacing parts

During the driving time after the running-in period, if the tires, braking devices, etc. are replaced with new parts, they must be run-in again according to the relevant regulations.

2.1.2 Vehicle cleaning

I. Vehicle cleaning

To protect the vehicle and maintain it in the best condition, perform the following manual cleaning operations:

1. Rinse the vehicle from top to bottom with a large amount of clean water to remove dust.
2. Wash the body of the vehicle with a sponge or soft cloth.
3. For hard-to-remove substances, first soften them with detergent and then rinse with clean water.
4. After washing, carefully dry the vehicle's paint surface with a soft towel.
5. Do not directly wash the front bumper grille with a high-pressure water gun, as non-professional washing can cause the radiator fins to collapse.

II. Automatic car wash

1. Before washing, fold the exterior rearview mirrors and close the windows completely.
2. Before washing, inform the staff that there is the LIDAR on the roof to assess whether it needs to avoid the LIDAR during washing.
3. It is best to use a fabric washing device when washing the vehicle to avoid damaging the paint.
4. Wash the vehicle from top to bottom, front to back.
5. After washing, carefully dry the vehicle's paint surface with a soft towel.
6. Before driving, make sure the exterior mirrors are unfolded.
7. After washing the vehicle, gently press the brake pedal several times in succession to remove any residual water from the brake discs. This can avoid affecting braking effectiveness and prevent rusting of the brake discs.

III. Cleaning the wheel hub

1. When removing stubborn stains, do not use hard brushes or abrasive cleaners.
2. Do not use detergent on hot wheel hubs.
3. After the wheel hubs cool down, you can use special wheel hub detergent. Rinse them off immediately after applying.

IV. Car lights

1. When cleaning car lights, do not dry wipe or use abrasive or corrosive detergents.
2. For stubborn dirt, first soften it with detergent and then wash it away with water.
3. Remove ice with deicing spray. Do not use a deicing shovel.

Warning

- Keep the charging port cover and tank cap closed during vehicle cleaning to avoid damage.
- Do not wax the surface of the car lights. Avoid damaging the car lights.
- High-pressure car washing with excessive water pressure may damage the paint.
- Do not rinse the vehicle's dust cover with a high-pressure water gun for a long time.
- Do not wash the high-voltage components at the bottom of the vehicle to avoid electrical shock or vehicle damage.

2.1.3 Vehicle maintenance

I. Vehicle paint

Regular daily maintenance helps ensure driving safety and vehicle value retention. Environmental factors such as air pollution or natural impurities (resin or pollen, etc.) in certain areas may affect vehicle paint. Adjust the frequency and scope of vehicle maintenance accordingly.

Remove corrosive substances such as spilled fuel, engine oil, lubricant, or bird droppings immediately to prevent paint discoloration or fading.

II. Leather curing

Regularly remove dust and impurities from the leather surface with a towel or vacuum cleaner.

When the leather is contaminated, clean it in time. First wipe the dirt with a tissue or towel, and then clean it with a little water on the towel. For stubborn stains, clean them with leather detergent. Finally dry the water stains on the surface.

Apply neutral care agent to the leather once a month for professional maintenance to maintain its quality.

A Caution

- Do not place sharp objects such as keys or scissors on the seats to avoid scratching or tearing the leather.
- Do not use alcohol, corrosive, acidic, or alkaline care agents, as they will damage the leather's protective layer.
- Do not turn on the seat heater to dry the seats. Do not treat the seat with an iron on the seats.
- Avoid soaking the seats with liquid.

III. Seat belt

Dirty seat belts may hinder retraction and affect safety performance. Seat belts should only be cleaned with mild soapy water. They can only be retracted when completely dry.

A Caution

- Do not use bleach, dyes or cleaning solvents, as these can reduce the durability of the seat belts.
- Always wait for the seat belt to completely dry before retracting it. Avoid damaging the seat belt retractor.

IV. Wheel

To maintain the beautiful appearance of the wheel hubs over the long term, the wheels require regular maintenance. It is recommended to thoroughly clean the wheels every two weeks to prevent fine abrasive particles, dirt or salt from solidifying on them after braking, which could otherwise corrode the wheels.

V. Underbody protection

The vehicle's underbody is treated to withstand chemical and mechanical damage. However, damage to the protective layer is inevitable during driving. It is advisable to check the vehicle's underbody and chassis protection layer at regular intervals, preferably before winter and in spring, and make necessary repairs if required.

2.1.4 Anti-corrosion

I. Common factors affecting vehicle corrosion

- Accumulated dirt, sand or ice under the body of the vehicle may accelerate corrosion.
- Industrial pollution, salt in the air in coastal areas and excessive road salt may accelerate the corrosion process of the paint.
- Increased temperature may accelerate the corrosion of poorly ventilated parts.
- Driving in high relative humidity or hot and humid environments may accelerate corrosion.
- Damage to the coating or other protective layers caused by sandstone impact or minor accidents may accelerate corrosion.

II. Anti-corrosion measures

- Wash the car regularly to keep it clean.
- Regularly check the paint for damage and repair it promptly.
- If you frequently drive on roads with snow-melting salt, salt-alkali soils or coastal areas with salt-containing roads, you should at least clean off any attachments from the bottom of the car every month.
- If the vehicle accumulates insects, asphalt, cement or other similar substances, clean them off promptly.

2.2 Regular maintenance

2.2.1 Regular maintenance

Regular and correct maintenance is clearly the best way to guarantee vehicle performance and safety functions, ensure respect for the environment and low operating costs.

The Scheduled Maintenance services listed in this manual must be done within the times or mileages specified to protect your vehicle warranty and ensure the best vehicle performance and reliability. More frequent maintenance may be needed for vehicles in operating conditions, such as dusty or muddy areas, extremely hot or cold ambient temperatures. Inspection and service should also be done anytime a malfunction is suspected. It's recommends that these maintenance intervals be performed at an ROX Service Center. The technicians at your Dealership know your vehicle best, and have access to factory-approved information, genuine ROX parts, and specially designed electronic and mechanical tools.

A Caution

- Remember that the observance of the maintenance procedures is essential for keeping your vehicle operating properly. Not adhering to the Maintenance Schedule or failure to have the services carried out can impact your vehicle's warranty.
- You are advised to notify the ROX Service Center of any minor operating problem, without waiting for the next scheduled service.
- Failure to perform the required maintenance items may result in damage to the vehicle.
- All maintenance operations for the vehicle must be carried out by a ROX Service Center. For routine and minor maintenance operations which you can carry out yourself, make sure that you have the necessary experience and always use suitable equipment, genuine ROX spare parts. Shall this not be the case, do not carry any operation on your own and contact a ROX Service Center.

2 Maintenance and repair

Operation Maintenance Schedule	Interval: 10000km/ 1 year (whichever comes first)										
	1	2	3	4	5	6	7	8	9	10	Notes
Check with ROX Diagnosis	I	I	I	I	I	I	I	I	I	I	
Engine Oil & Filter (Extender)	R	R	R	R	R	R	R	R	R	R	Extender working period and mileage
Engine Coolant Level	I	I	I	I	I	I	I	I	I	I	
						R					Replace every 6 years/120000km
Engine Checks for Leaks	I	I	I	I	I	I	I	I	I	I	
Air Filter (Extender)		R		R		R		R		R	Extender working period and mileage
Pollen Filter	R	R	R	R	R	R	R	R	R	R	Replace every 1 year/20000km
Spark Plugs				R				R			Extender working period and mileage
Brake Fluid				R				R			Replace every 4 years/80000km
Brake System (pipelines, calipers, connections, pads, DTC)	I	I	I	I	I	I	I	I	I	I	
Tire Wear, Tire Pressure Check	I	I	I	I	I	I	I	I	I	I	
Joints Rods for Front and Rear Suspensions & Chassis	I	I	I	I	I	I	I	I	I	I	
Correct Operation and Reliability of the Seats and Seat belt	I	I	I	I	I	I	I	I	I	I	
Windshield Fluid Level	I	I	I	I	I	I	I	I	I	I	
Headlight Leveling	I	I	I	I	I	I	I	I	I	I	
Controls and Adjustment in General, Hinges, Doors, Lids, luggage Compartment etc.	I	I	I	I	I	I	I	I	I	I	

I = Inspect and carry out any other necessary operation
R = Replace
Only 10 intervals schedule is presented, the following intervals can refer to these 10 intervals period and dedicated Parts Maintenance Schedule as following

2 Maintenance and repair

Maintenance Item	Maintenance cycle (subject to time or mileage, whichever comes first)	
	Time	Mileage
Engine oil, oil filter maintenance for range extender system	1 years	Range extender has worked for 10,000 km
Air filter for range extender system	2 years	Range extender has worked for 20,000 km
Air conditioning filter	1 year	20,000 km
Spark plug	—	Range extender has worked for 40,000 km
Brake fluid	4 years	80,000 km
Coolant	6 years	120,000 km

2.3 Self-maintenance

2.3.1 Hood

I. Open the hood

1. Pull the engine hood unlock handle twice in succession to unlock the engine hood.

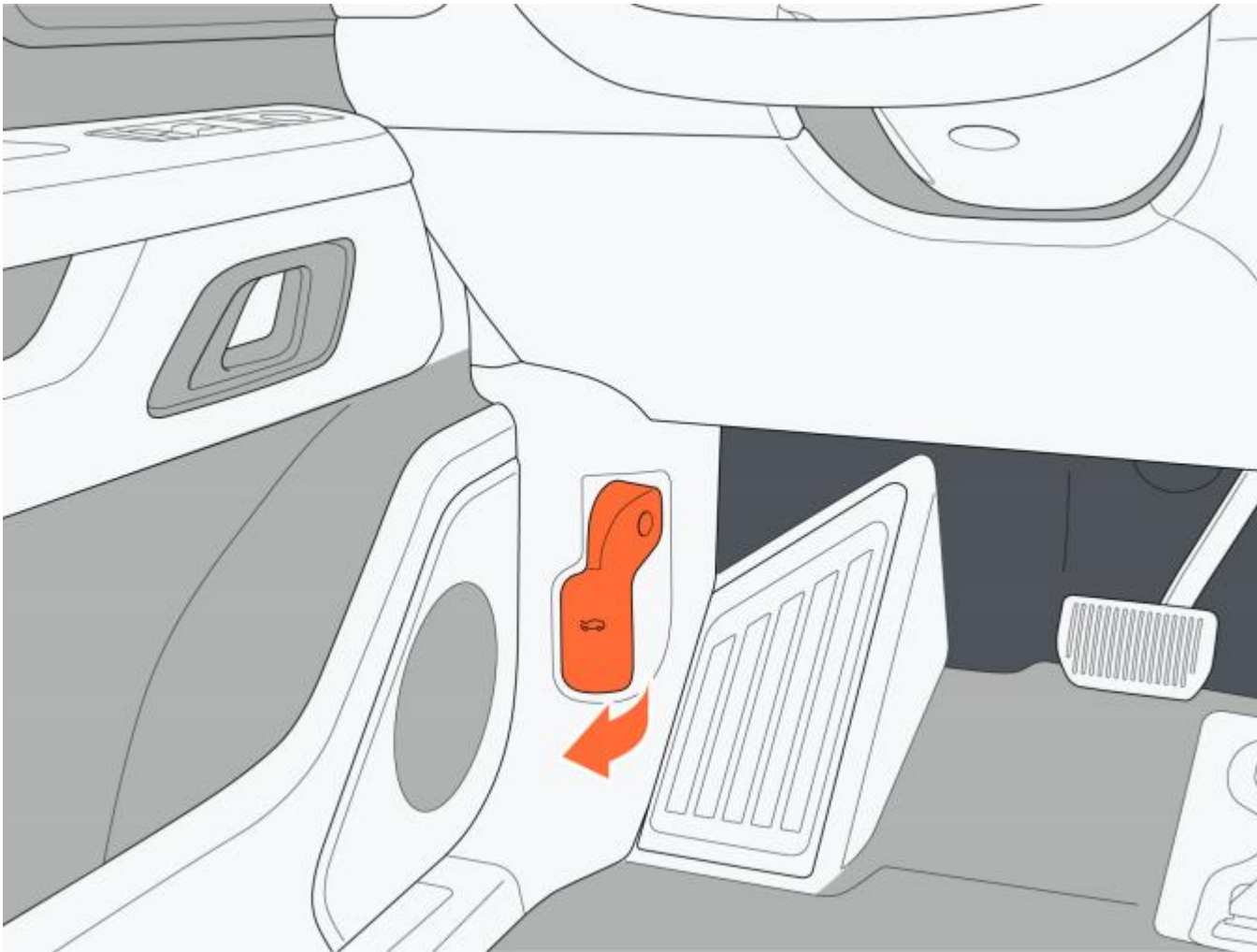

2 Maintenance and repair

2. After unlocking the engine hood, lift it up.

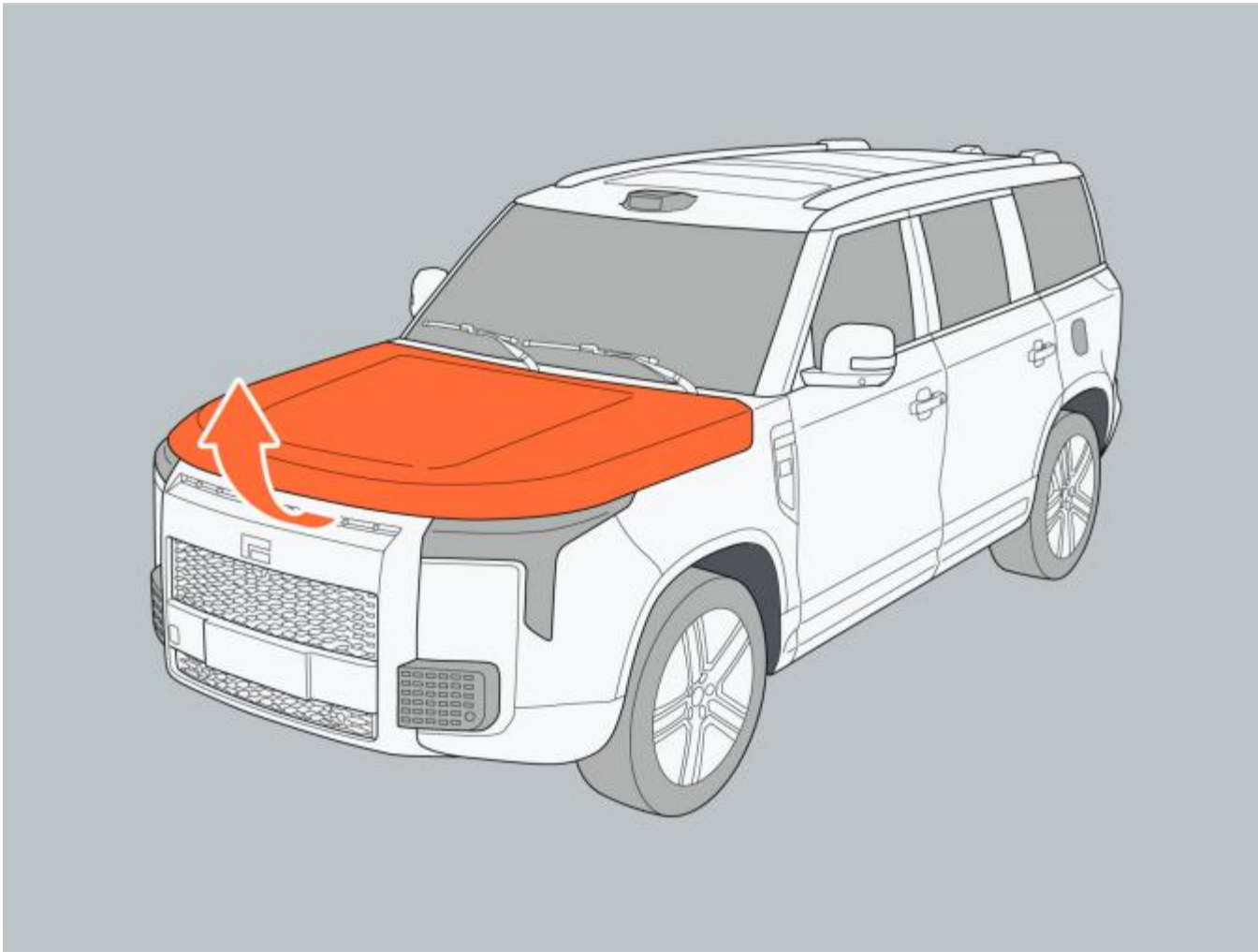

3. Close the hood

Lower the engine hood to allow it to close under its own weight. If the hood is not fully locked, press down firmly on the front end of the hood. After closing the engine hood, try to lift it slightly to ensure that it is fully locked.

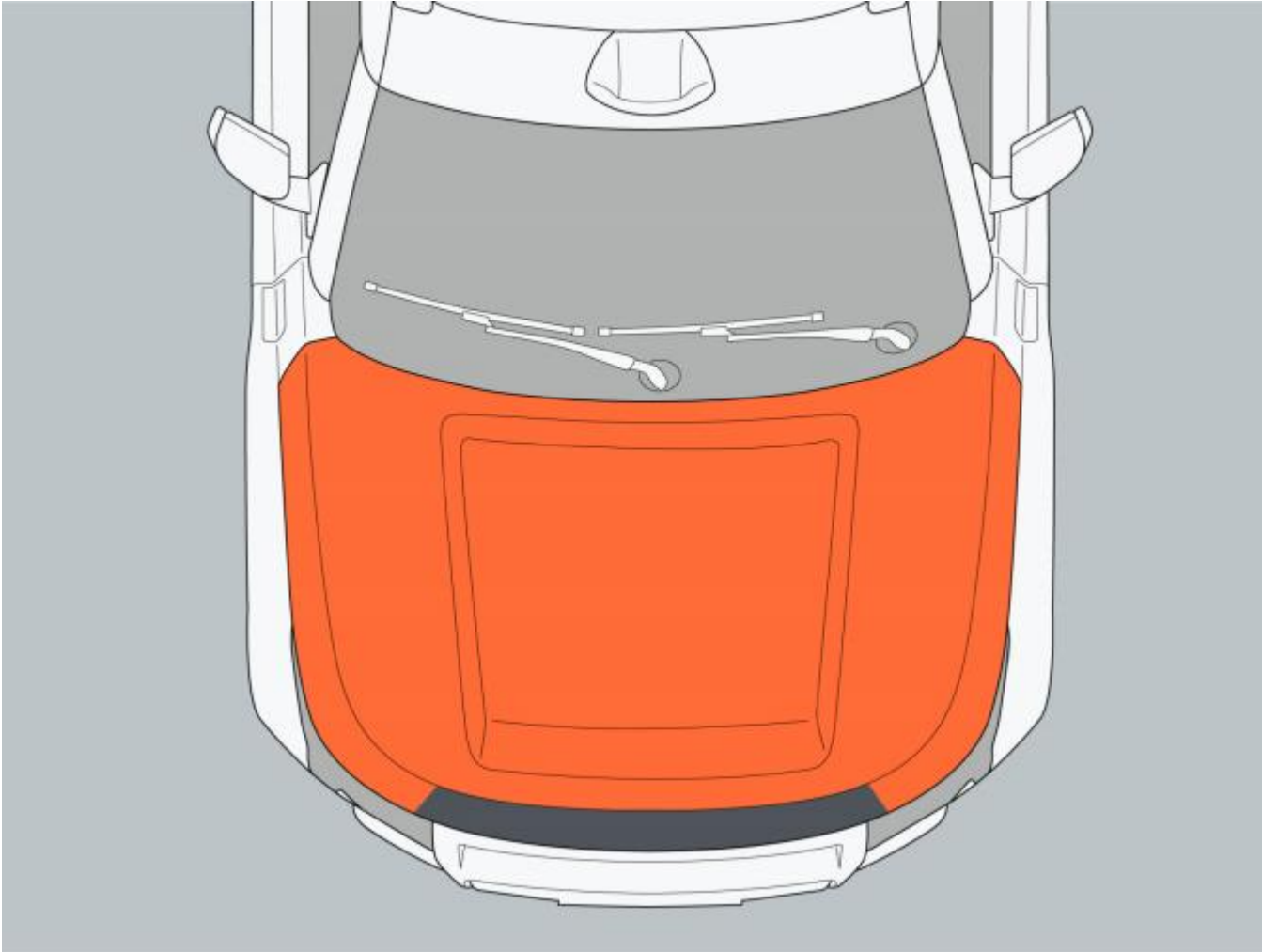

2.3.2 Engine compartment

I. Location of oil/fluid filling port

S/N	Name
1	Wiper fluid filling port
2	Power battery coolant filling port
3	Engine oil filling port
4	Brake fluid filling port
5	Range extender coolant filling port

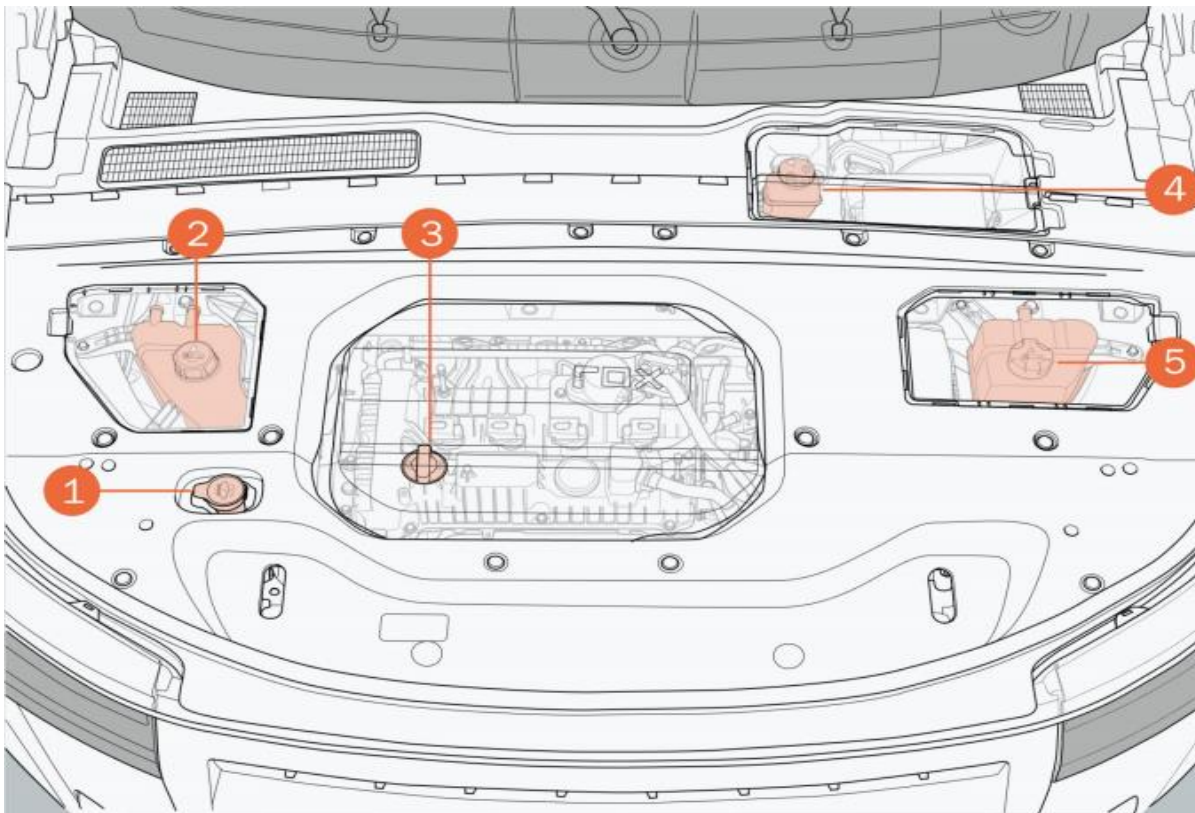

 **Warning**

- Do not open the range extender, drive motor and power battery integrated expansion water tank cap immediately after driving the vehicle to avoid burns.
- Do not place flammable materials such as paper or rags inside the engine compartment.
- Do not get close to parts that may move, such as fans and belts, to avoid personal injury or vehicle damage due to hands, clothing, or tools being entrapped suddenly.
- Do not allow the level of oil to be outside the normal filling mileage.
- Do not touch parts inside the engine compartment immediately after driving the vehicle to avoid burns.

2.3.3 Battery

I. Warning sign information



II. Battery position

The battery is located on the left side of the trunk. You can find it by taking out the luggage pad and removing the tool box.

III. When the battery fails

If the battery fault light appears on the instrument panel, it indicates that the battery is low charge or there is a fault in the battery system. Please contact the ROX Service Center promptly.

A Caution

- If a battery failure leads to the battery running out of charge and the vehicle cannot be started normally, please contact the ROX Service Center.
- This vehicle uses a lithium-ion battery. Do not connect an external power source to charge the battery, as this may damage the battery.
- Jump starting between this vehicle and another vehicle is prohibited to avoid damaging the battery.
- If it needs to replace a battery, contact the ROX Service Center. Do not attempt to replace the 12 V battery by yourself

2.3.4 LIDAR

To ensure the normal operation of the LIDAR, please regularly clean the LIDAR transceiver window.

Regular cleaning is the best way to protect the LIDAR transceiver window from harmful environmental effects. The cleaning interval depends on many factors (such as: usage frequency, vehicle storage in a parking lot, under a tree, season, climatic conditions, environmental impact, etc.). The longer insect residue, bird droppings, resin, road dust, industrial dust, asphalt, soot particles, deicing salt or other erosive deposits adhere to the transceiver window, the greater their damage. High temperatures (such as intense sunlight) can also exacerbate the erosive effects. After finding any of the above-mentioned corrosive substances on the LIDAR transceiver window, it should be cleaned immediately. Therefore, it may require cleaning once a week, but in some cases, it can also be cleaned once a month.

Warning

- When cleaning the LIDAR, ensure that the vehicle power is in the “OFF” mode to avoid eye damage from the LIDAR.

Caution

- Do not clean it with detergent containing alcohol or solvents (such as nitro diluents, cooling cleaners, fuel, etc.), as there is a risk of cracking the transceiver window.
- Do not clean the LIDAR transceiver window when it is dry. Never use a cleaning agent with polishing effect, as there is a risk of scratching or cracking.

2.3.5 Tire

I. Use of tire

To ensure driving safety and comfort, we remind you to read carefully and strictly follow the following precautions when driving your vehicle for the safety of yourself and your family:

- Choose to drive on roads with good conditions.
- During driving, stay focused and avoid obstacles such as bumps or depressions in front of you. If unavoidable, reduce your speed and drive slowly through them.
- Regularly check the tires for damage (such as cuts or cracks) and irregularly check abnormal wear.
- Maintain the correct tire pressure.

II. Tread depth

Wear marks are located on the tire's circumference, with the legal minimum depth being 1.6 mm.



When the tires wear down to the wear mark, replace them promptly to avoid insufficient grip.

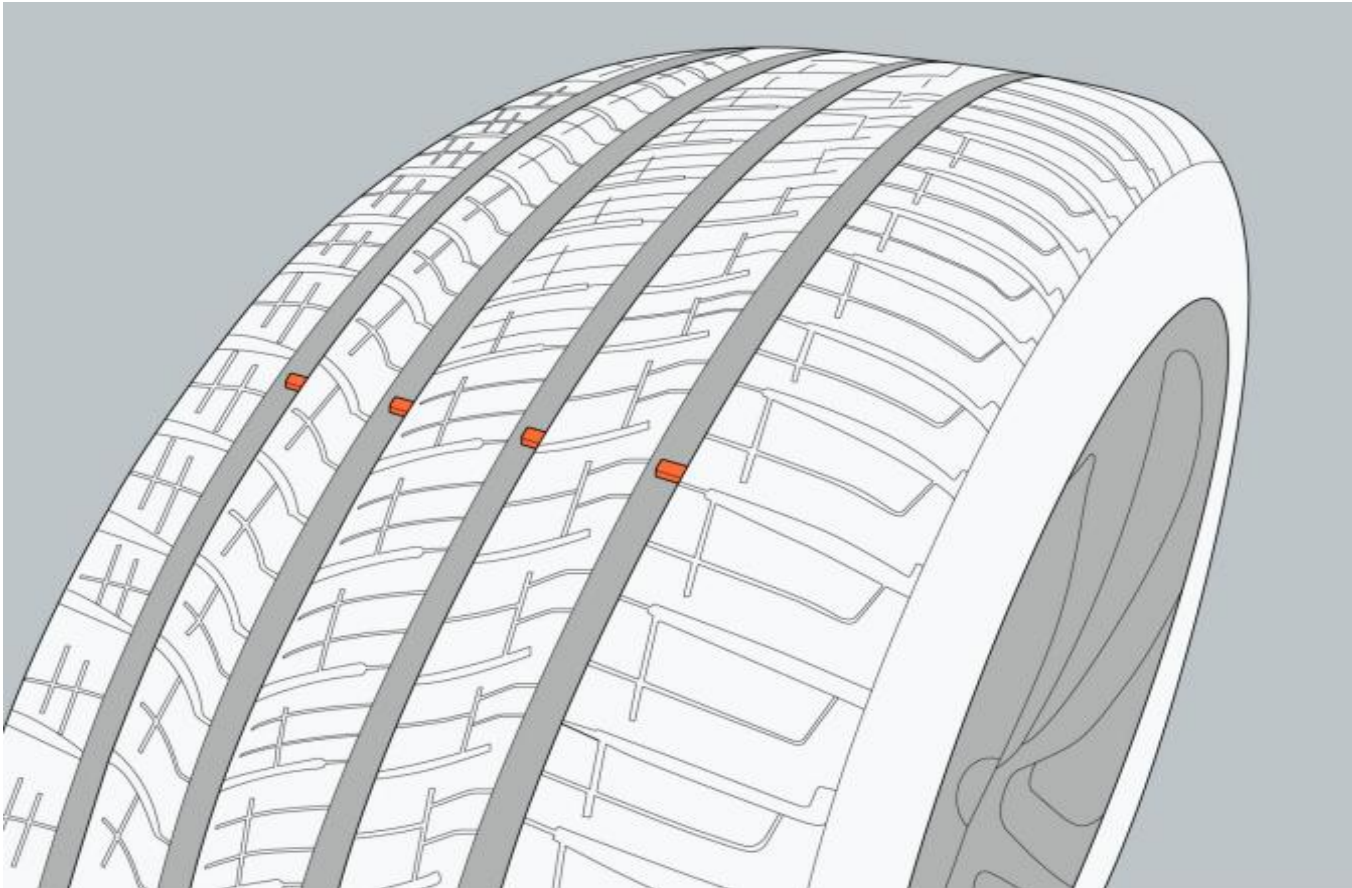

III. Tire inspection

For your driving safety, please regularly check the tires for the following, and contact the ROX Service Center for a re-inspection and replacement if any damage or irregularities are found or suspected.

- Check if the tire tread is unevenly worn. Remove any foreign objects from the tread (such as stones, glass, etc.).
- Check if the tread has worn down to the point where the wear mark is exposed.
- Prevent the tires from contacting engine oil, grease or fuel.
- If the dust cover on the tire valve is missing, replace it as soon as possible.

Warning

- Do not use retreaded tires or tires with unknown age
- The four tires should be of the same model, tread pattern and manufacturer.
- After tire replacement, the tires must be checked for dynamic balance.
- Replacing only one tire will severely affect the vehicle's handling.
- Driving over obstacles quickly, such as hitting curbs or road damage, may cause tire damage.
- Larger wheels have a smaller tire cross-section. When the tire cross-section is small, the risk of tire damage will increase, and there is a danger of accidents and damage to objects. Try to avoid obstacles or drive slowly and carefully

IV. Tire storage

After replacing tires, store the unused tires properly:

1. Please make sure to store the tires in a cool, dry place.
2. Tires without rims should be stored upright.
3. Prevent the tires from coming being contaminated with engine oil, grease, fuel and solvents.

V. Four-wheel rotation

To ensure even tire wear and extend the tire's service life, it is recommended to rotate the tires every approximately 10,000 km by end user.

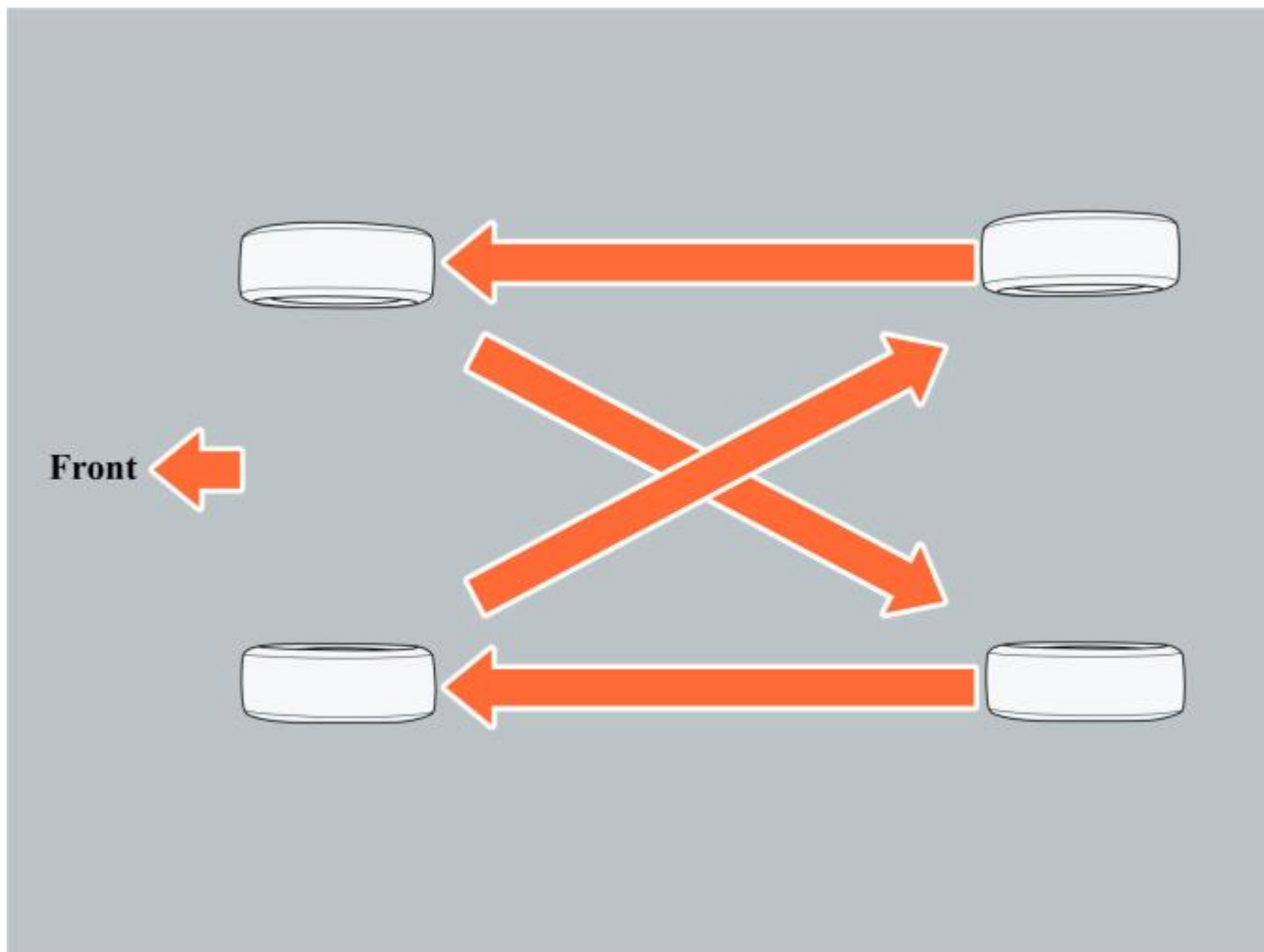

2.3.6 Tire pressure

I. Tire pressure label

The tire pressure label is located on the rim of the driver's door, and the tire pressure shown on the label is the cold tire pressure value.

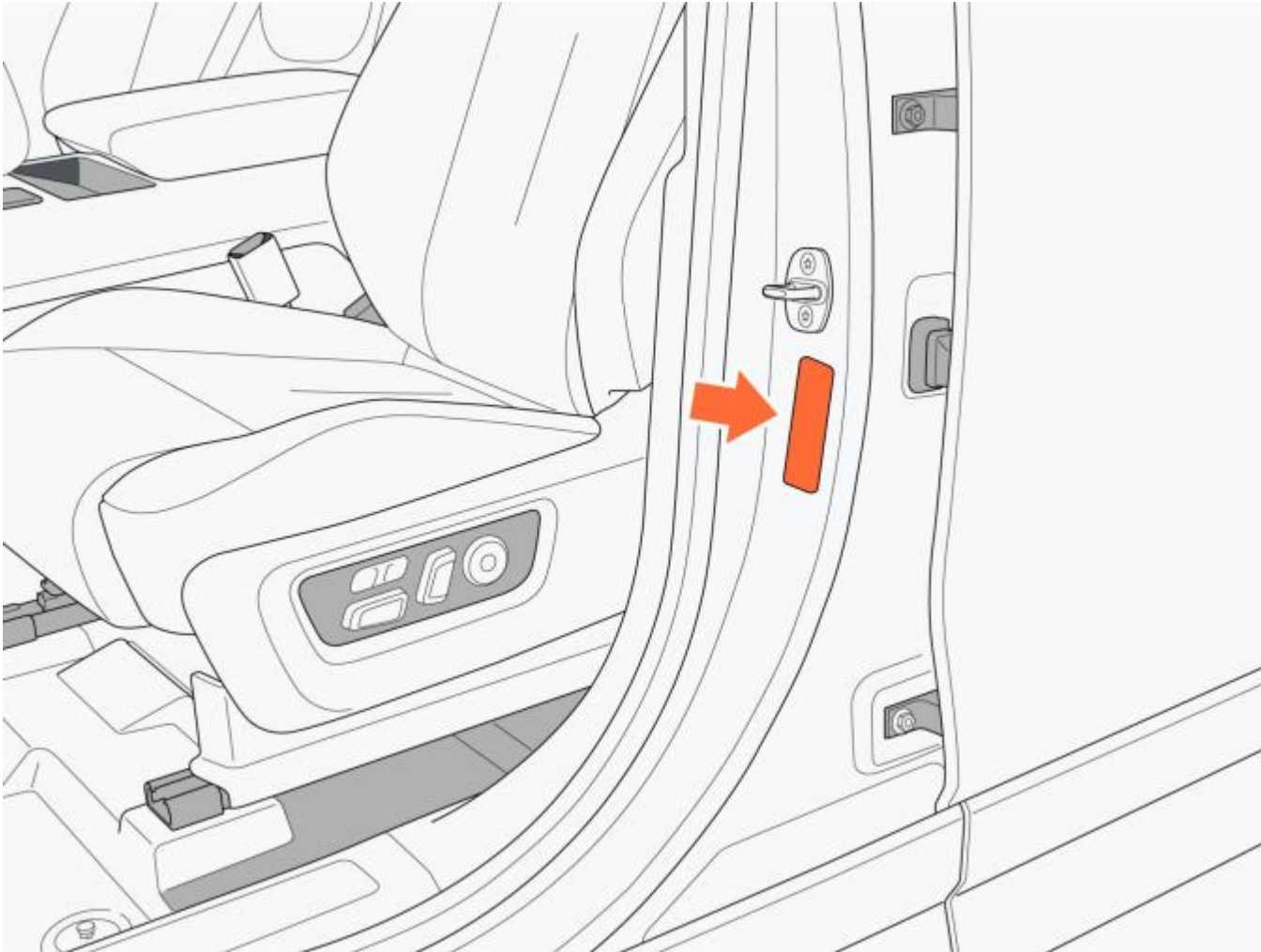

II. Tire pressure check

When checking tire pressure, observe the following:

- It is recommended to check tire pressure at least once a month.
- When checking tire pressure, the vehicle should be parked for at least 3 h or have not driven more than 2 km, as this will allow for a more accurate measurement of the tire's cold tire pressure.
- Tire pressure will be higher than the cold tire pressure when driving, which is a normal phenomenon.
- Do not check tire pressure after long periods of driving.

III. Abnormal conditions

When tire pressure is abnormal, the following conditions may occur:

- Reduction in driving comfort and maneuverability.
- Uneven tire wear.
- Decreased safety.

A Caution

- When a tire deflates, park the vehicle in a safe area and contact the ROX Service Center promptly.

2.3.7 Wheel

When the tires are deformed, cracked, or severely corroded, they should be replaced promptly, as this may affect the vehicle's comfort or lead to loss of control due to wheel failure.

I. Tire selection

When replacing tires, it is important to ensure that the tires to be replaced have the same load capacity and size as the original tires. The ROX Service Center does not recommend using:

- Tires of different specifications or types.
- Tires with an unclear age or production date.
- Corrected tires.
- Retreaded tires.

II. Tire replacement

1. Always use the wheel bolts specified by ROX or equivalent products designed specifically for aluminum rims.
2. When performing a dynamic balance, please use the balance weights specified by ROX or equivalent products.

A Caution

- The repair or replacement of tires may affect the normal operation of the tire pressure monitoring system. Therefore, when you need to repair or replace your tires, please contact the ROX Service Center.
- Make sure to use parts specified by ROX or equivalent in specification.

2.3.8 Air conditioning filter

Check and replace A/C filters regularly according to maintenance plan. If the vehicle is driven in dusty areas or busy traffic areas, it is advisable to shorten the replacement interval for the A/C filter.

If the air flow from the vehicle's air vents is weak or there is an unpleasant odor when A/C is turned on, it may indicate that the A/C filter is clogged or has foreign objects. Check the A/C filter and replace it if necessary.

2.3.9 Windshield wiper

Wiper check

1. Contaminants on the windshield or wiper blades can reduce the utility of the wiper blades. Contaminants include ice, car wash spray wax, cleaning solutions containing bacteria and/or waterproofing agents, bird droppings, tree sap and other organic substances.
2. Check if the wiper blades are worn or broken.
3. Check if there is any unusual noise when the wiper blades are in operation.

Wiper maintenance

1. If the wiper blades are not working properly or show signs of wear, clean the windshield and wiper blades with mild detergent, then rinse with clean water and replace them as needed.
2. Only use cleaning products that are certified for use on automotive glass and rubber. Improper use may cause damage or contamination, leading to glare on the windshield.

A Caution

- Do not use the wipers when the windshield is dry or when the wiper fluid container is empty.
- Before turning on the windshield wipers, thoroughly defrost and clear the snow from the windshield.
- Before washing the car, ensure that the windshield wipers are in the off position.
- Allowing the wiper arm to contact the windshield without a wiper blade installed may damage the windshield. Any damage resulting therefrom is not covered by the vehicle warranty. Do not allow the wiper arm contact the windshield.

Wiper replacement

1. After lifting the wiper arm, place a thicker towel under the lower part of the wiper arm against the windshield to prevent the wiper arm from accidentally bouncing back and damaging the windshield.
2. After lifting the wiper arm, press the lock locking clips on the left and right sides of the wiper, then pull the wiper forward.
3. After replacing the wiper, gently place the wiper arm back on the windshield.



Tip

The replacement method for the wiper on the left and right sides is the same as the rear window wiper

2.3.10 Remote-control key battery

When the battery power is too low or dead, replace the battery with a new one. Otherwise, some functions of the remote key will be restricted (e.g., starting the system, remote control functions cannot be used normally, etc.).

I. Replace the battery

1. Pinch the trim cover on both sides and pull it outwards in the direction of the arrow.

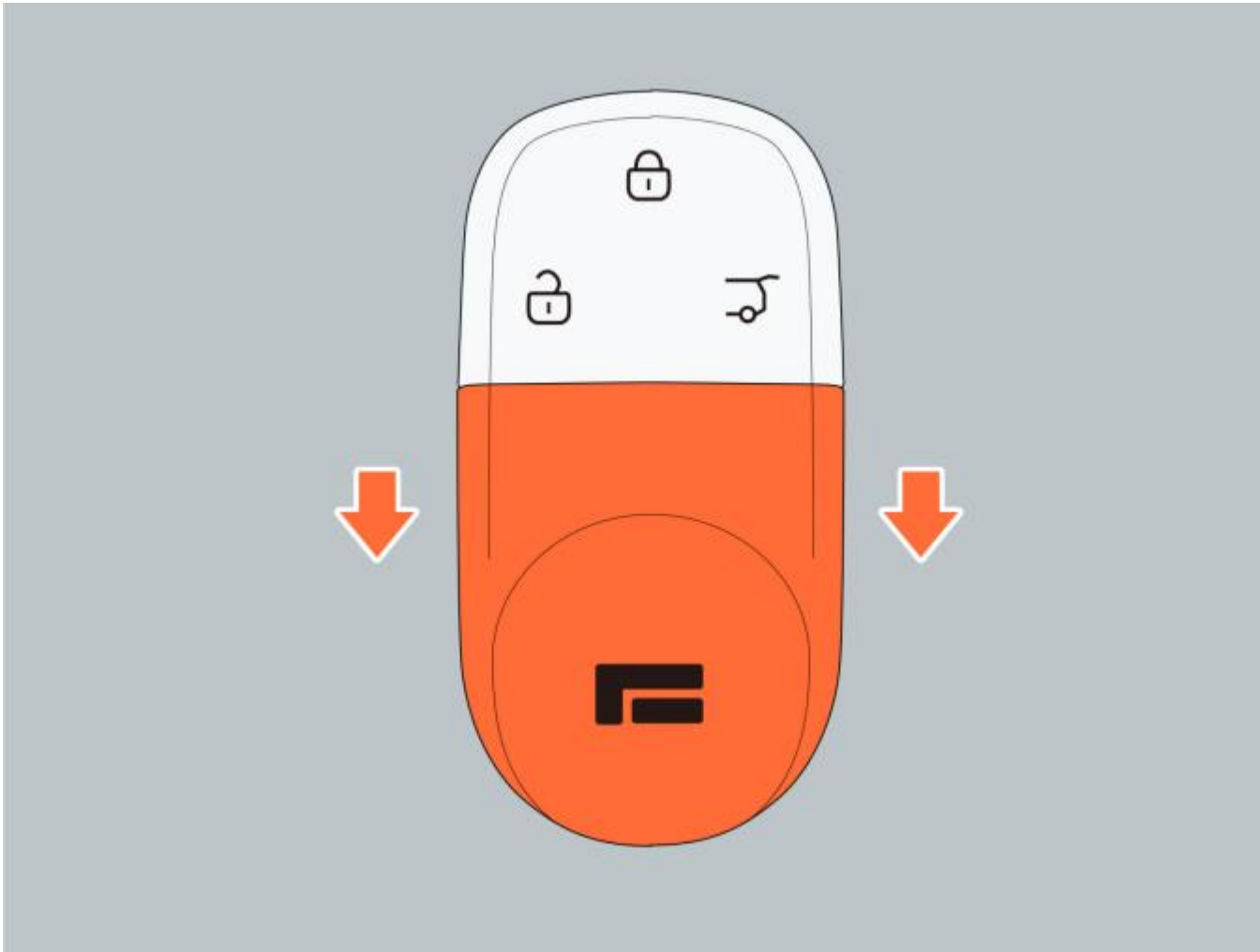

2 Maintenance and repair

2. After removing the trim cover, gently pry the gaps on both sides of the bracket with a small flathead screwdriver or a similar tool and separate the panel component.



2 Maintenance and repair

3. After separating the panel component, remove the button battery, and install it with the positive terminal facing down.

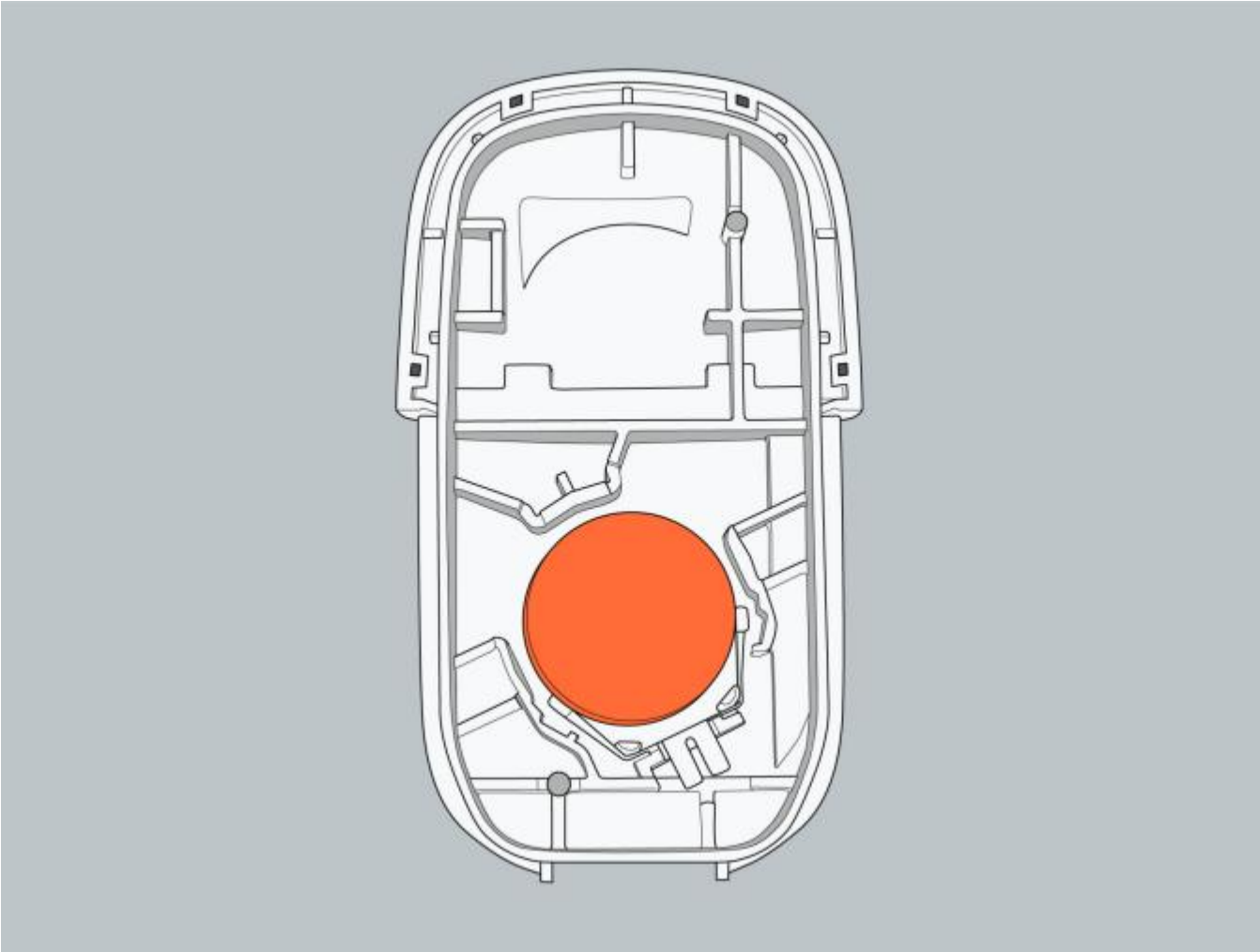

4. After the battery is installed, assemble it in reverse order of the disassembly steps.

Warning

- Place the battery in a location where children cannot reach to prevent accidental swallowing it.
- When installing the battery, avoid sweat or water on your hands to prevent the battery from rusting and damaging the remote key.

Tip

- When the battery needs to be replaced, it is recommended to have a technician from the ROX Service Center to replace it.
- Button Battery (model: CR2032).

Eco-friendly

- The battery contains toxic substances and corrosive materials. Please dispose of the exhausted battery at a qualified professional service center or recycling outlet for used batteries.

2.3.11 Check and replace the fuse

Fuses protect automotive electrical equipment by preventing overload in the circuit. A fuse that has blown indicates that the circuit it was protecting has a fault and is no longer working.

If a fuse is blown, please contact the ROX Service Center to replace the blown fuse promptly.

Warning

- Do not use conductor or other conductive items as substitutes for fuses, as they may not melt in time, leading to circuit damage or even a fire.
- Do not modify the fuse or fuse box.

2.4 Vehicle long-term parking

2.4.1 Vehicle long-term parking

I. Parking place

When the vehicle needs to be parked for a long period, try to park on a flat road. It is recommended to park in a dry, well-ventilated environment away from sources of heat and corrosive substances, and to use a car cover. This helps slow down the aging of rubber parts and paintwork.

II. Ambient temperature

To maintain the vehicle's good performance, avoid exposing the vehicle to an environment above 55°C or below -30°C for more than 24 h.

III. Battery

When the vehicle detects that the battery voltage is too low, the intelligent charging function is triggered, and the battery will be charged through the power battery. Therefore, when the vehicle is restarted after being parked for a long time, the remaining mileage displayed on the central control screen will decrease, which is a normal phenomenon.

IV. Power battery

- Before the vehicle is parked for a long time, confirm that the power battery's charge is within a relatively sufficient mileage (50% ~ 70%).
- The vehicle must be maintained at least once every three months. It is recommended to charge the battery to 50%~70% before parking. If it exceeds three months, the power battery charge needs to be charged up to 70%, and then the vehicle can be parked.
- Before using the vehicle again after it has been parked for more than three months, please check the instrument panel for any battery alarms. If any, please contact the ROX Service Center.



Tip

- For vehicles that are not used for a long time, regular maintenance is essential to prevent irreversible battery damage.
- We recommend that you check the battery charge every week and drive the vehicle once a month. If the battery charge is insufficient, please arrange for a charge before parking it.
- If the vehicle is continuously parked and not used for more than 3 months without regular maintenance of the power battery by following the manual's instructions, it will not be covered by the warranty.
- If OTA is frequently used to remotely control the vehicle during long-term parking, it will increase the power consumption of the vehicle and accelerate power loss. Users should shorten the vehicle maintenance cycle and avoid long-term parking under low battery conditions.
- When the power battery's charge is too low, the system will remind the user to charge the power battery through the APP.
- In the event of the vehicle being submerged in water due to weather or special reasons, do not turn on the vehicle's power, as this may cause safety risks or secondary damage to the vehicle.
- Avoid vehicles wading over long distances or for long periods of time.

2.5 Vehicle Maintenance Record

<p style="text-align: center;">Maintenance Record</p> <p>Date: Mileage: Repair Order: Remarks:</p> <p>Service Center Service Seal</p>	<p style="text-align: center;">Maintenance Record</p> <p>Date: Mileage: Repair Order: Remarks:</p> <p>Service Center Service Seal</p>	<p style="text-align: center;">Maintenance Record</p> <p>Date: Mileage: Repair Order: Remarks:</p> <p>Service Center Service Seal</p>
<p style="text-align: center;">Maintenance Record</p> <p>Date: Mileage: Repair Order: Remarks:</p> <p>Service Center Service Seal</p>	<p style="text-align: center;">Maintenance Record</p> <p>Date: Mileage: Repair Order: Remarks:</p> <p>Service Center Service Seal</p>	<p style="text-align: center;">Maintenance Record</p> <p>Date: Mileage: Repair Order: Remarks:</p> <p>Service Center Service Seal</p>
<p style="text-align: center;">Maintenance Record</p> <p>Date: Mileage: Repair Order: Remarks:</p> <p>Service Center Service Seal</p>	<p style="text-align: center;">Maintenance Record</p> <p>Date: Mileage: Repair Order: Remarks:</p> <p>Service Center Service Seal</p>	<p style="text-align: center;">Maintenance Record</p> <p>Date: Mileage: Repair Order: Remarks:</p> <p>Service Center Service Seal</p>

2 Maintenance and repair

<p style="text-align: center;">Maintenance Record</p> Date: Mileage: Repair Order: Remarks: Service Center Service Seal	<p style="text-align: center;">Maintenance Record</p> Date: Mileage: Repair Order: Remarks: Service Center Service Seal	<p style="text-align: center;">Maintenance Record</p> Date: Mileage: Repair Order: Remarks: Service Center Service Seal
<p style="text-align: center;">Maintenance Record</p> Date: Mileage: Repair Order: Remarks: Service Center Service Seal	<p style="text-align: center;">Maintenance Record</p> Date: Mileage: Repair Order: Remarks: Service Center Service Seal	<p style="text-align: center;">Maintenance Record</p> Date: Mileage: Repair Order: Remarks: Service Center Service Seal
<p style="text-align: center;">Maintenance Record</p> Date: Mileage: Repair Order: Remarks: Service Center Service Seal	<p style="text-align: center;">Maintenance Record</p> Date: Mileage: Repair Order: Remarks: Service Center Service Seal	<p style="text-align: center;">Maintenance Record</p> Date: Mileage: Repair Order: Remarks: Service Center Service Seal

2.6 Vehicle Status Record

Vehicle Inspection

Performed during the 1st year of operation



Mark the inspection results with appropriate symbols

◇ Dent

○ Body Damage

× Scratch

△ Paint Damage

General condition of Vehicle

- Excellent
- Good
- Satisfied
- Bad

The previously discovered damage has been repaired

- Yes
- No

Comments:

Date

Odometer mileage (kilometers): KM

Service Center Seal and Signature

Owner's signature

2 Maintenance and repair

Vehicle Inspection

Performed during the 2nd year of operation



General condition of Vehicle

- Excellent
- Good
- Satisfied
- Bad

The previously discovered damage has been repaired

- Yes
- No

Comments:

Date

Odometer mileage (kilometers): KM

Service Center Seal and Signature

Owner's signature

Mark the inspection results with appropriate symbols

- ◇ Dent
- Body Damage
- × Scratch
- △ Paint Damage

2 Maintenance and repair

Vehicle Inspection

Performed during the 3rd year of operation



Mark the inspection results with appropriate symbols

◇ Dent

○ Body Damage

× Scratch

△ Paint Damage

General condition of Vehicle

- Excellent
- Good
- Satisfied
- Bad

The previously discovered damage has been repaired

- Yes
- No

Comments:

Date

Odometer mileage (kilometers): KM

Service Center Seal and Signature

Owner's signature

2 Maintenance and repair

Vehicle Inspection

Performed during the 4th year of operation



Mark the inspection results with appropriate symbols

◇ Dent

○ Body Damage

× Scratch

△ Paint Damage

General condition of Vehicle

- Excellent
- Good
- Satisfied
- Bad

The previously discovered damage has been repaired

- Yes
- No

Comments:

Date

Odometer mileage (kilometers): KM

Service Center Seal and Signature

Owner's signature

2 Maintenance and repair

Vehicle Inspection

Performed during the 5th year of operation



Mark the inspection results with appropriate symbols

◇ Dent

○ Body Damage

× Scratch

△ Paint Damage

General condition of Vehicle

- Excellent
- Good
- Satisfied
- Bad

The previously discovered damage has been repaired

- Yes
- No

Comments:

Date

Odometer mileage (kilometers): KM

Service Center Seal and Signature

Owner's signature

2.7 Odometer replacement

Odometer replacement card

If the odometer malfunctions, please contact the official ROX Dealer's service center for replacement.

Odometer replacement record

Date of replacement: _____

Old odometer mileage (km): _____

New odometer mileage (km): _____

Service Center Name: _____

Service Center Seal and Signature:

Odometer replacement card

If the odometer malfunctions, please contact the official ROX Dealer's service center for replacement.

Odometer replacement record

Date of replacement:

Old odometer mileage (km):

New odometer mileage (km):

Service Center Name:

Service Center Seal and Signature:



Global After-Sales Email: after-sales-global@roxmotor.com